



# EAST WIGHT COMBINED CLUBS REGATTA SERIES 2020



Lead Club

Supporting Club



## ~~OPTIMIST TRAVELLER SERIES REGATTA~~

~~Saturday 25<sup>th</sup> & Sunday 26<sup>th</sup> April~~



## ~~MOCRA SERIES~~

~~Sunday 10<sup>h</sup> May, 7<sup>h</sup> June, 5<sup>h</sup> July, 19<sup>h</sup> July, 6<sup>h</sup> September &  
4<sup>h</sup> October~~



## ~~INTER CLUB SCOW TEAM RACING~~

~~Friday 1<sup>st</sup> May~~



## ~~175<sup>th</sup> ANNIVERSARY SERIES~~

~~Saturday 23<sup>rd</sup> & Monday 25<sup>th</sup> May~~



## ~~IW DINGHY CHAMPIONSHIPS~~

~~Saturday 20<sup>th</sup> & Sunday 21<sup>st</sup> June~~



## ~~J70 REGATTA~~

~~Saturday 11<sup>th</sup> & Sunday 12<sup>th</sup> July~~



## ~~BEMBRIDGE VILLAGE REGATTA~~

~~(Bembridge Harbour Family Fun Weekend)~~

~~Saturday 1<sup>st</sup> August~~



## ~~INTERNATIONAL OPTIMIST OPEN REGATTA~~

~~Sunday 16<sup>th</sup> August~~



## ~~INTERNATIONAL LASER OPEN REGATTA~~

~~Sunday 16<sup>th</sup> August~~



## ~~SOLENT SCOW CHAMPIONSHIPS~~

~~Sunday 16<sup>th</sup> August~~



## ~~INTERNATIONAL LASER TEAM RACING~~

~~Thursday 20<sup>th</sup> August~~



## ~~BEMBRIDGE SAILING CLUB REGATTA~~

~~Friday 21<sup>st</sup> and Saturday 22<sup>nd</sup> August~~



## ~~SEA VIEW YACHT CLUB REGATTA~~

~~Sunday 23<sup>rd</sup> and Monday 24<sup>th</sup> August~~



## ~~BRADING HAVEN YACHT CLUB REGATTA~~

~~(incorporating the Mermaid Gin Regatta)~~

~~Sunday 23<sup>rd</sup> August - Dinghies~~

~~Saturday 29<sup>th</sup> and Sunday 30<sup>th</sup> August - Keelboats~~



## ~~MOCRA BEMBRIDGE REGATTA~~

~~Saturday 12<sup>th</sup> & Sunday 13<sup>th</sup> September~~



## ~~NATIONAL SQUIB SOUTH COAST CHAMPIONSHIPS~~

~~Saturday 12<sup>th</sup> & Sunday 13<sup>th</sup> September~~



## ~~ROYAL VICTORIA YACHT CLUB REGATTA~~

~~(Merrydown Regatta)~~

~~Saturday 19<sup>th</sup> & Sunday 20<sup>th</sup> September~~



## EAST WIGHT COMBINED CLUBS

[www.ewcc.co.uk](http://www.ewcc.co.uk)

President	Colin Samuelson
Chairman	Mark Downer
Hon Race Officer	Jonathan Peel
Hon Secretary	Mike Samuelson ( <i>mikesam06@gmail.com</i> )

<b>Bembridge Sailing Club</b> (01983-872237) <a href="http://bembridgesailingclub.org">bembridgesailingclub.org</a> <a href="mailto:sec@bembridgesailingclub.org">sec@bembridgesailingclub.org</a>	Commodore	Jonathan Nainby-Luxmoore
	Vice-Commodore	Charles Abel Smith
	Rear-Commodores	Crispin Kenyon (Sailing) Nigel Rawlence (House) Jim Conybeare-Cross (Finance)
	Club Manager	Gemma Wall
	Sailing Manager	Hazel Wilson
<b>Brading Haven Yacht Club</b> (01983-872289) <a href="http://bhyc.org.uk">bhyc.org.uk</a> <a href="mailto:secretary@bhyc.org.uk">secretary@bhyc.org.uk</a>	Commodore	Jeff Cowan
	Vice-Commodore	
	Rear-Commodores	Polly Schafer (Offshore) Jan Baum (Onshore) John Whitehead (Finance)
	Club Manager/Secretary	John Maher
<b>Royal Victoria Yacht Club</b> (01983-882325) <a href="mailto:office@rvyc.org.uk">office@rvyc.org.uk</a>	Commodore	Chris Rickman
	Vice-Commodore	Helen Vrba
	Rear-Commodores	Jane Barrett Bellingham (Sailing) Rachel Wroath (House)
	Hon Secretary	Carol McDonnell
	Hon Treasurer	Tracy Rickman
	Club Manager	Rachel Leal
<b>Sea View Yacht Club</b> (01983-613268) <a href="mailto:secretary@svyc.org.uk">secretary@svyc.org.uk</a> <a href="mailto:training@svyc.org.uk">training@svyc.org.uk</a>	Commodore	John Edwards
	Vice-Commodore	Kate Broxham
	Rear-Commodores	Ben Few Brown (Sailing) Fiona Conway-Hughes (House)
	Hon Treasurer	Richard Bowtell
	Club Secretary	tbc
	Sailing Director	Jon Curtis

East Wight Combined Clubs exists as a Committee created jointly by Bembridge Sailing Club, Brading Haven Yacht Club, Royal Victoria Yacht Club and Sea View Yacht Club to co-ordinate the race management of keelboat and dinghy regattas organised by them in the Eastern Solent.

The Flag Officers of Bembridge Sailing Club, Brading Haven Yacht Club, Royal Victoria Yacht Club and Sea View Yacht Club invite all competitors and their supporters to be Associate Members and use the facilities of the Clubs during these Regattas.

Please note that the information contained in this programme/booklet may need to be amended as the Covid-19 guidelines change. Where possible the Regattas will follow a common approach, however the responsibility for following the Covid-19 guidelines falls to the organising Club, so competitors must ensure that they are aware of any special requirements before entering the Regatta.

## **ENTRY REQUIREMENTS FOR EAST WIGHT REGATTAS**

Entrants for any race in the East Wight Series must have signed a 2020 Entry Form which includes agreement to be bound by the "Risk Statement" in EWCC SI 22 on page 28 and that they consent to their entry details being held by the organising Club in accordance with that Club's Data Protection policy.

Entrants for handicap races will additionally be required to provide information about their boat and either an IRC or ISC handicap or Portsmouth Yardstick number.

Entry Forms will be available on request through Class Secretaries or from the Club Secretaries/Club Managers of the respective Clubs.

The Entry Form for entrants under 18 **must** be endorsed by a parent/guardian.

The Club Annual Entry Forms available from BHYC, BSC, SVYC & RVYC are applicable for any race in the East Wight Series. The respective clubs will, on request, provide the Organising Authority with a list of helms/boats in the specified classes who have validly signed an Entry Form.

Entrants must also have paid the relevant entry fee, if any, prior to any race they enter.

Keelboats that appear in the vicinity of the Starting Line prior to their Preparatory Signal will be considered as Starters, provided they have complied with these entry requirements.

*In addition to complying with these entry requirements, entrants in centreboard dinghies (including small multihulls) must sign the Sign-On Sheet for each race/event in which they compete in accordance with the requirements of the REGISTRATION & BRIEFING section of the relevant Notice of Race.*

Clubs of the EWCC implement the RYA Racing Charter and competitors will be required to undertake to sail in compliance with the Charter, which can be found at the front of the RYA rule book (Racing Rules of Sailing 2017-2020) or at

***<http://www.rya.org.uk/racing/Pages/RacingCharter.aspx>***

In addition to the events included in this programme, some clubs may be ~~running events to support the RYA 'Push the Boat Out' during May. Additionally,~~ supporting "Barts Bash" on Saturday or Sunday 12<sup>th</sup>/13<sup>th</sup> September.

## **NOTICES OF RACE & SAILING INSTRUCTIONS**

Notices of Race and Sailing Instructions and Conditions of Entry can be downloaded from the EWCC website ([www.ewcc.co.uk](http://www.ewcc.co.uk)) except for the following events which, whilst part of the East Wight Regatta Series, are governed by the Class Rules of their National Authority and will be issued separately; they can also be obtained from the organising Club or downloaded as shown below.

EVENT	CLUB	WEBSITE
National Squib South Coast Championships	RVYC	<a href="https://www.rvyc.org.uk">https://www.rvyc.org.uk</a>

## 2020 COURSES AND OTHER OPEN EVENTS

Date	Courses	Host club(s)	Open events	Host club(s)
15 Mar 20	VHF Exam	SVYC		
5 Apr 20	First Aid	SVYC		
6 to 9 Apr	Easter supported training/sailing/VHF/PB2	BSC		
13 to 15 Apr	Easter supported training/sailing	BSC		
16 Apr	First Aid	BSC		
29 Apr	ICC (Sailing) exam	SVYC		
3 May	First Aid	SVYC		
9 May	Club Race Officers course	SVYC		
23 & 27 May	Half-term training incl PB2	SVYC		
23 & 29 May	Half-term supported sailing/training/PB2	BSC		
6 Jun			Open Day for people with disabilities	RVYC
15 to 18 Jun	Powerboat Instructors course	SVYC		
20 to 26 Jun	DI course	SVYC		
21 Jun			Prince Philip's Cup	SVYC
23 Jun			SVYC v BHYC v RVYC v RSoIYC	SVYC
27 Jun	VHF exam	SVYC		
29 June to 2 Jul	SI course	SVYC		
5 to 10 Jul	DI course	SVYC		
6 to 9 Jul	First Aid, PB2, VHF	BSC		
11 Jul			Cadet Regatta & BBQ	RVYC
12 to 17 Jul	DI course	SVYC		
13 to 15 Jul	First Aid/Safety Boat	BSC		
13 & 14 Jul	DI Multihull endorsement	SVYC		
13 to 16 July	Powerboat Instructors course	SVYC		
16 & 17 Jul	Advanced Instructor	SVYC		
19 Jul	First Aid	SVYC		
19 to 23 Jul			Cadet Week 1 Training Week 1	BSC
20 to 24 Jul			All members week	SVYC
20 to 24 Jul	DI Course	SVYC		
22 & 23 Jul	DI Keelboat endorsement	SVYC		
26 to 31 Jul	Keelboat Instructors course	SVYC		
27 to 31 Jul			Adult Week	SVYC
27 to 31 Jul	Supported sailing/training/PB2/VHF	BSC		
2 to 6 Aug			Cadet Week 2 Training Week 2	BSC
10 to 14 Aug			Junior Cadet Week	SVYC
3 to 7 Aug			Senior Cadet Week	SVYC
10 - 13 Aug	Supported sailing/training	BSC		
11 Aug			Scow Parade	BSC
17 to 19 Aug			Seaview Race Week	SVYC
17 to 21 Aug	Sprits Week	SVYC	All Cadets Week	SVYC
17 to 21 Aug			Cadet Week 3 Training Week 3	BSC
17 to 21 Aug			Dinghy Week	BHYC
19 to 22 Aug			Cadet Week	RVYC
12 or 13 Sep			Bart's Bash	All clubs
13 Sep	VHF exam	SVYC		
20 Sep	First Aid	SVYC		
3 Oct			Illusion Winter Series starts	BSC
5 to 9 Oct	Navigation theory (all levels)	SVYC		
7 & 8 Nov	PB2/Safety Boat	RVYC		
18 Oct			Barrel Race	RVYC
18 to 30 Oct	Half-term supported sailing/training	BSC		
1 Nov to 20 Dec			Frostbite Open Series	RVYC



# RVYC MOCRA INVITATION SERIES 2020 NOTICE OF RACE

## **ORGANISATION**

This event is part of the East Wight Combined Club's series. The Organising Authority will be RVYC.

## **CONDITIONS OF ENTRY & ENTRY FEE**

Entrants must complete and return to the RVYC (by e mail: [office@rvyc.org.uk](mailto:office@rvyc.org.uk)) a 2020 Entry Form available from the RVYC website before racing ([www.rvyc.org.uk](http://www.rvyc.org.uk)) which can be downloaded from <http://www.ewcc.co.uk>.

There is no entry fee.

All boats shall have a valid 2020 MOCRA Rating Certificate.

## **REGISTRATION & BRIEFING**

Registration will be by radio (VHF Ch. M1) to the RVYC Race Officer (call sign: VIC Race Officer) once entrants are in the vicinity of the race course.

There will be no briefing.

## **SAILING INSTRUCTIONS**

Races shall be governed by the World Sailing Racing Rules of Sailing 2017 - 2020, RYA Prescriptions, MOCRA

Rules, this Notice of Race and the Sailing Instructions. RVYC SIs will apply as varied by this Notice of Race. SI's can be downloaded from the RVYC website.

Unless modified by the RO before racing the Class Flag **M (MOCRA)** will be used 5 minutes prior to the start time.

## **PROGRAMME OF EVENTS**

Date	HW ( <i>Portsmouth</i> )	Timings	Events
<b>10<sup>th</sup> May</b>	HW 14:22 (4.7m)	Start 13:30	Race 1
<b>7<sup>th</sup> June</b>	HW 13:17 (4.7m)	Start 12:00	Race 2
<b>5<sup>th</sup> July</b>	HW 12:19 (4.5m)	Start 11:00	Race 3
<b>19<sup>th</sup> July</b>	HW 11:40 (4.3m)	Start 10:30	Race 4
<b>6<sup>th</sup> September</b>	HW 14:59 (4.5m)	Start 14:00	Race 5
<b>4<sup>th</sup> October</b>	HW 13:54 (4.6m)	Start 12:30	Race 6

## **SAILS, EQUIPMENT CHECKS & SAFETY**

Boats shall comply with the current World Sailing Special Regulations for Category 4 races, except that regulations 3.13.1 (crash bulkheads), 3.15.2(c) and (d) (netting triangles), 3.14.4(c) (trimaran outrigger lines) and 3.14.4(d) (lifelines on catamarans) shall not apply. Spot checks to establish conformity with Class Rules may be made at the direction of the Race Committee before, during or after the series.

## **INSURANCE**

Each participating boat shall be insured with valid third-party liability insurance with a minimum cover of £2,000,000.

## **COURSES & RACE FORMAT**

The race course will be in the central and eastern Solent, between W Ryde Middle Buoy to the West and Kemps Quay buoy to the East. All racing marks will be on the 2020 RVYC Race Chart which can be downloaded from the RVYC website.

All races may be run as an Average Lap format at the discretion of the Duty Race Officer. For these races, competitors are required to repeat the course as notified to include the start/finish line at the end of each lap. Competitors will finish when the shortened course flag is displayed as they cross the start/finish line (irrespective of the number of laps completed). Clarification if necessary will be provided on VHF Ch M1.

## **STARTING**

The start line will either use the RVYC race box, or a committee boat on the defined race course area.

Races will be started in accordance with RRS 26.

## **EXONERATION PENALTY, ADVISORY HEARING & RYA ARBITRATION**

The exoneration Penalty and Advisory Hearing & RYA Arbitration of the RYA Rules Disputes Procedures will be available.

## **SCORING**

Low Point Scoring System (RRS Appendix A) will apply. There will be one discard if 4 or more races are completed.

## **PRIZES**

Providing there are sufficient entries, a trophy (provided by RVYC) will be awarded to the winner of the series, and will be presented at the MOCRA AGM and/or prize giving.

## **COMMUNICATIONS**

Race Information - Ch M1; Race Management - M2;

## **BERTHING**

Berthing can be arranged the night before, and/or after by contacting the RVYC Office.

## **MEALS**

The RVYC bar and galley will be open at the times advertised on the website.

Jane Barrett Bellingham  
Rear Commodore (Sailing), RVYC

N Talbot  
for MOCRA

# INTERNATIONAL OPTIMIST CLASS OPEN REGATTA

Sunday 16<sup>th</sup> August

## NOTICE OF RACE

<i>HIGH &amp; LOW WATER PORTSMOUTH (BST)</i>		
	HW	LW
Sunday 16 <sup>th</sup> August	10:37 (4.1m)	15:32 (1.7m)

### **ORGANISATION**

This event is part of the EWCC's Series. The Organising Authority will be SVYC.

### **ELIGIBILITY & ENTRY**

Helms must be members of an affiliated RYA Club. The Entry Requirements on page 2 of this programme, which includes agreement to be bound by the "Risk Statement" in EWCC SI 22 on page 28, apply. There is no Entry Fee.

### **REGISTRATION & BRIEFING**

In addition to complying with the entry requirements, to the **entrants must sign the Sign-On Sheet at SVYC or BSC prior to the briefings at 10:00**. Failure to do so will result in the boat not being recognised as racing.

### **RULES & SAILING INSTRUCTIONS**

Races shall be governed by the World Sailing Racing Rules of Sailing. Races will be sailed under the East Wight Sailing Instructions, as varied by this Notice of Race. They can be downloaded from <http://www.ewcc.co.uk>

Protests must be notified to the Race Officer immediately after each race. Protest forms must be lodged with the Race Officer within 2 hours of the completion of racing. Rule 44.1 is changed so that the Two-turns Penalty is replaced by a One-turn Penalty.

### **PROGRAMME OF EVENTS**

		Flag	Start
Sunday 16 <sup>th</sup> August	Registration & Briefing at SVYC & BSC		10:00
	Race 1	O	11:30
	Race 2	O	oc
	Race 3	O	oc

### **COURSES**

Racing will be from a Committee Boat. The position of the Committee Boat and the course to be used will be issued at the briefing.

### **SAILS & EQUIPMENT CHECKS**

Spot checks to establish conformity with Class Rules may be made at the direction of the Race Committee before, during or after the Regatta.

### **SAFETY**

When the race committee considers that a boat or a competitor is in difficulty, it may instruct the boat or competitor to accept outside help, retire and sail ashore.

**SUPPORT BOATS** - are welcome but should not interfere with the racing unless required to rescue a boat in trouble.

**SCORING SYSTEM** - the Low Point Scoring System (RRS Appendix A) will apply. There will be one discard allowed if all 3 races per fleet are sailed, none if only 2 are sailed.

**RESULTS** - will be posted on the Notice Board at the SVYC as soon as possible after the day's racing.

**PRIZES** - Prizes will be available at SVYC on completion of racing. Due to Covid-18 restrictions there will not be a formal prize giving.

**BOAT PARKING AND ACCESS** - boat parking is available in SVYC's Duver Dinghy Park; limited spaces may be available on the SVYC staging. Launching ramps are located at the Duver Dinghy Park, SVYC Staging and the Halland slipway.

J Curtis - Sailing Director SVYC

# INTERNATIONAL LASER CLASS OPEN REGATTA

Sunday 16<sup>th</sup> August

## NOTICE OF RACE

<i>HIGH &amp; LOW WATER PORTSMOUTH (BST)</i>		
	HW	LW
Sunday 16 <sup>th</sup> August	10:37 (4.1m)	15:32 (1.7m)

### ORGANISATION

This event is part of the EWCC's Series. The Organising Authority will be SVYC.

### ELIGIBILITY & ENTRY

Helms must be members of an affiliated RYA Club. The Entry Requirements on page 2 of this programme, which includes agreement to be bound by the "Risk Statement" in EWCC SI 22 on page 28, apply. There is no Entry Fee.

### REGISTRATION & BRIEFING

In addition to complying with the entry requirements, to the **entrants must sign the Sign-On Sheet at SVYC, BHYC or BSC prior to the briefings at 10:00**. Failure to do so will result in the boat not being recognised as racing. The Rig size must be included on the entry form and the same Rig is to be used in each race. Failure to do so will invalidate a boats entry.

### RULES & SAILING INSTRUCTIONS

Races shall be governed by the World Sailing Racing Rules of Sailing. Races will be sailed under the East Wight Sailing Instructions, as varied by this Notice of Race. They can be downloaded from <http://www.ewcc.co.uk>

Protests must be notified to the Race Officer immediately after each race. Protest forms must be lodged with the Race Officer within 2 hours of the completion of racing. Rule 44.1 is changed so that the Two-turns Penalty is replaced by a One-turn Penalty.

### PROGRAMME OF EVENTS

		Flag	Start
Sunday 16 <sup>th</sup> August	Registration & Briefing at SVYC, BSC & BHYC		10:00
	Race 1 (Full & Radial)	V	11:30
	Race 1a (4.7)	1	11:35
	Race 2 (Full & Radial)	V	oc
	Race 2a (4.7)	1	oc
	Race 3 (Full & Radial)	V	oc
	Race 3a (4.7)	1	oc

### COURSES

Racing will be from a Committee Boat. The position of the Committee Boat and the course to be used will be issued at the briefing.

**SAILS & EQUIPMENT CHECKS** - Spot checks to establish conformity with Class Rules may be made at the direction of the Race Committee before, during or after the Regatta.

**SAFETY** - When the race committee considers that a boat or a competitor is in difficulty, it may instruct the boat or competitor to accept outside help, retire and sail ashore.

**SUPPORT BOATS** - are welcome but should not interfere with the racing unless required to rescue a boat in trouble.

**SCORING SYSTEM** - the Low Point Scoring System (RRS Appendix A) will apply. There will be one discard allowed if all 3 races per fleet are sailed, none if only 2 are sailed.

**RESULTS** - will be posted on the Notice Board at the SVYC as soon as possible after the day's racing.

**PRIZES** - Prizes will be available at SVYC on completion of racing. Due to Covid-18 restrictions there will not be a formal prize giving.

**BOAT PARKING AND ACCESS** - boat parking is available in SVYC's Duver Dinghy Park; limited spaces may be available on the SVYC staging. Launching ramps are located at the Duver Dinghy Park, SVYC Staging and the Halland slipway.

J Curtis - Sailing Director SVYC



# SOLENT SCOW CHAMPIONSHIP

Sunday 16<sup>th</sup> August

## NOTICE OF RACE

<i>HIGH &amp; LOW WATER PORTSMOUTH (BST)</i>		
	HW	LW
Sunday 16 <sup>th</sup> August	10:37 (4.1m)	15:32 (1.7m)

### **ORGANISATION**

This event is part of the East Wight Combined Clubs' Series. The Organising Authority will be BSC with race management assistance provided by BHYC.

### **ELIGIBILITY & ENTRY**

**Helms must be members of an affiliated RYA Club.** The Entry Requirements on page 2 of this programme, which includes agreement to be bound by the "Risk Statement" in EWCC SI 22 on page ??, apply. There is no Entry Fee.

### **REGISTRATION & BRIEFING**

In addition to complying with the entry requirements, entrants **must sign the Sign-On Sheet at BSC or BHYC at least 30 minutes before the scheduled race start time.** Failure to do so will result in the boat not being recognised as racing. There will not be a briefing.

### **RULES & SAILING INSTRUCTIONS**

Races shall be governed by the World Sailing Racing Rules of Sailing 2017 - 2020, RYA Prescriptions, Class Rules, this Notice of Race and the Sailing Instructions. Races will be sailed under the East Wight Sailing Instructions, as varied by this Notice of Race. They can be downloaded from <http://www.ewcc.co.uk>. Class flags are as shown below. Races will be started in accordance with RRS 26. Rule 44.1 is changed so that the Two-turns Penalty is replaced by a One-turn Penalty.

### **PROGRAMME OF EVENTS**

Date	Race	Flag	Start
Sunday 16 <sup>th</sup> August	Race 1	7	09:50
	Race 2	7	As soon as possible after Race 1

### **COURSES**

Courses will be in vicinity of St Helens Fort.

### **SAILS & EQUIPMENT CHECKS**

Spot checks to establish conformity with Class Rules may be made at the direction of the Race Committee before, during or after the Regatta.

**SUPPORT BOATS** - these are welcome but are governed by EWCC SI 18.1 unless required to rescue a boat in trouble.

**SCORING SYSTEM** - the Low Point Scoring System (RRS Appendix A) will apply. No discard.

**RESULTS** - results will be posted on the Notice Board at BSC & BHYC after racing.

**PRIZES** - prizes will be available at BSC after racing. Due to Covid-18 restrictions there will not be a formal prize giving.

**1st Prize Overall** - Solent Scow Championship Cup and a prize

**Scows 2nd & 3rd** (4th & 5th depends on numbers of entrants) - a prize each

**1st Under 18 Helm** - a prize

C Kenyon

Rear Commodore (Sailing) BSC

# IOW INTER CLUB YOUTH LASER TEAM RACING

Thursday 20<sup>th</sup> August

## NOTICE OF RACE

<i>HIGH &amp; LOW WATER PORTSMOUTH (BST)</i>		
	HW	LW
Thursday 20 <sup>th</sup> August	13:13 (4.8m)	18:27 (1.1m)

### **ORGANISATION**

This event is part of the East Wight Combined Clubs' Series. The Organising Authority will be SVYC assisted by BSC.

### **ELIGIBILITY & ENTRY**

Helms must be under 21 years and members of an affiliated RYA Club. The Entry Requirements on page 2 of this programme, which includes agreement to be bound by the "Risk Statement" in EWCC SI 22 on page 28, apply.

The Entry Fee is £20 per team of 2 people who shall sail together, one person to a boat. The Entry fee includes a bacon butty on arrival at SVYC prior to the briefing.

The event will be sailed in Laser 1s, using Radial rigs approved by the organising authority and provided by the competing teams. Up to eight teams with a maximum of two teams representing an individual club will be invited to take part in the regatta.

All entries must be received by SVYC by Monday 17<sup>th</sup> August; these must be received in writing. The Entry Form is available from the SVYC sailing office.

### **REGISTRATION & BRIEFING**

Registration will be on Thursday 20<sup>th</sup> August between 09:00 and 10:00. All competitors **must complete registration at the SVYC sailing office before going afloat**. The briefing prior to sailing will be at 10:15 and attendance by competitors is mandatory.

All team members under the age of 18 on 20<sup>th</sup> August 2020 must produce a completed Parent/Guardian consent and declaration form; without this form Sailors will **not** be allowed to complete registration.

### **RULES & SAILING INSTRUCTIONS**

Races shall be governed by the World Sailing Racing Rules of Sailing, including Appendix D, Team Racing Rules.

RRS D2.6 - Limited Umpiring - shall apply; this changes RRS D2.2 and RRS 2.5.

The right of appeal will be denied in accordance with RRS 70.5a.

RRS 14 (Avoiding Contact) shall be deemed to apply at all times whether racing or not and shall apply to all sailing boats in the event.

The boats shall conform to their class rules, however radial sails approved by the organising authority may be used.

Competitor advertising will not be permitted unless approved by the organising authority. Boats may be requested to display advertising chosen and supplied by the organising authority.

Copies of the sailing instructions will be available at registration and may also be found on the SVYC website [www.svyc.org.uk](http://www.svyc.org.uk) or EWCC website [www.ewcc.co.uk](http://www.ewcc.co.uk)

**SCHEDULE** - the schedule of races will be issued at the briefing. Each team will race each of the other club teams (but not their own). Time of the warning signal for the first race will not be before 11.00.

**VENUE** - racing will take place off Seaview.

**COURSES** - the course will be confirmed at the briefing but is likely to be a "M" course (see next page) using Inflatable marks.

### **PERSONAL FLOTATION DEVICES**

All competitors shall wear adequate personal flotation devices at all times while afloat except briefly while changing or adjusting clothing or personal equipment.

Any participants suffering an injury shall report the matter to an umpire of the race committee immediately. That person may be required to proceed ashore immediately to receive first aid.

### **PENALTY SYSTEM**

A boat that, while *racing*, may have broken a rule of Part 2 (except rule 14 (avoiding contact) when she has caused damage or injury), or rule 42, may take a **270°** Penalty (**gybe upwind, tack downwind**) - modifies

RRS 44.2. When a boat takes the penalty at or near the finishing line, she shall sail completely to the course side of the line before *finishing*.

An umpired penalty will be signalled with a Red flag and the offending boat shall take a **360°** Penalty.

*Penalties must be taken as soon as possible after the incident - they may not be delayed or left until a more convenient moment!*

### **SCORING**

Each boat finishing a race, whether or not rule 28.1 has been complied with, shall be scored points equal to her finishing place **except for last place and boats retiring which shall score 5 points**. In the event of two or more teams having the same number of wins, the result of the race between those two teams will determine the order. In the event that this does not break the draw, the order will be determined on the number of points scored.

**SUPPORT BOATS** - Support boats are welcome but are governed by EWCC SI 18.1 unless required to rescue a boat in trouble.

**RADIO COMMUNICATIONS** - except in an emergency, a boat shall neither make radio transmissions while racing nor receive radio communications not available to all boats. This restriction also applies to mobile telephones.

**PRIZES** - prizes will be available at SVYC after racing has finished. Due to Covid-18 restrictions there will not be a formal prize giving.

**BOAT PARKING AND ACCESS** - Boat parking is available in the SVYC Dinghy Park.

### **FURTHER INFORMATION**

For further information on this Regatta contact *Jon Curtis* (Director of Sailing SVYC).

J Curtis - Sailing Director SVYC

### **COURSE**

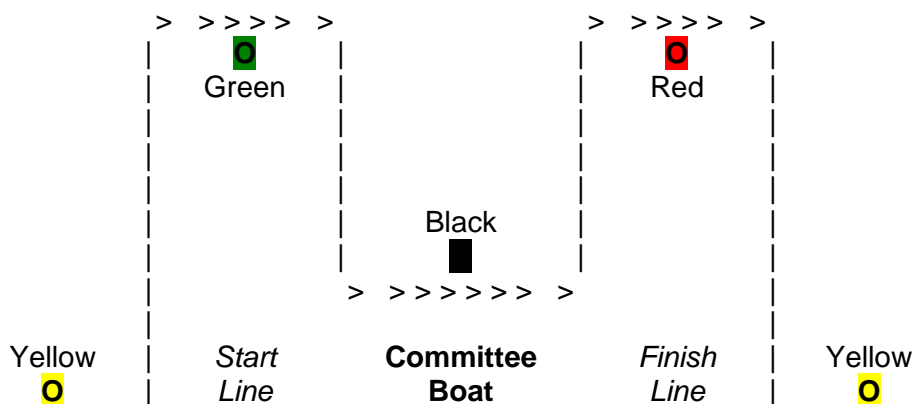

# BEMBRIDGE SAILING CLUB REGATTA

Friday 21<sup>st</sup> and Saturday 22<sup>nd</sup> August

## NOTICE OF RACE

<i>HIGH &amp; LOW WATER PORTSMOUTH (BST)</i>		
	HW	LW
Friday 21 <sup>st</sup> August	13:57 (4.9m)	19:17 (0.6m)
Saturday 22 <sup>nd</sup> August	14:43 (4.9m)	19:59 (0.7m)

### ORGANISATION

This event is part of the East Wight Combined Clubs' Series. The Organising Authority will be BSC with race management assistance provided by SVYC and BHYC.

### ELIGIBILITY & ENTRY

Helms must be members of an affiliated RYA Club. The Entry Requirements on page 2 of this programme and the Disclaimer of Liability in EWCC SI 21 on page 28 apply. There is no Entry Fee.

### REGISTRATION & BRIEFING

In addition to complying with the entry requirements, entrants in centreboard dinghies (incl multihulls) **must sign the Sign-On Sheet for their class at BSC, BHYC or SVYC at least 30 minutes before the scheduled race start time.** Failure to do so will result in the boat not being recognised as racing. PYs for entrants in Dinghy Class Races 3 & 5 and sail sizes for Race 4 **MUST** be entered on the appropriate Sign-On Sheet. There will not be a briefing.

### RULES & SAILING INSTRUCTIONS

Races shall be governed by the World Sailing Racing Rules of Sailing 2017 - 2020, RYA Prescriptions, Class Rules, this Notice of Race and the Sailing Instructions. Races will be sailed under the East Wight Sailing Instructions, as varied by this Notice of Race. They can be downloaded from <http://www.ewcc.co.uk>

Class flags are as shown below. Races will be started in accordance with RRS 26; however, for the *Keelboat Classes* there will be a 5 minute gap between the start of each Class and the warning for the next one - this modifies RRS 26. Rule 44.1 is changed so that the Two-turns Penalty is replaced by a One-turn Penalty.

### PROGRAMME OF EVENTS

<b>Keelboat Classes</b>				
Race	Class	Flag	Fri 21 <sup>st</sup> Aug	Sat 22 <sup>nd</sup> Aug
1	Handicap Cruiser	2	12:50	13:50
2	Redwing	R	13:00	14:00
3	Bembridge One Design	NN8	13:10	14:10
4	National Squib	NN9	13:20	14:20
5	Seaview Mermaid	U	13:30	14:30

<b>Dinghy Classes</b>				
Race	Class	Flag	Fri 21 <sup>st</sup> Aug	Sat 22 <sup>nd</sup> Aug
1	International Optimist	O	13:00	14:00
2	Solent Scow	7	13:05	14:05
3	Dinghy Handicap (PY 1250 and over)	4	13:10	14:10
4	International Laser 1 (4.7)	V	13:15	14:15
5	RS Feva	F	13:20	14:20
6	Dinghy Handicap (under PY 1250)	3	13:25	14:25

### COURSES

**Keelboat Classes** - races will start from a Committee Boat Starting Line positioned off St Helens Fort.

**Dinghy Classes** - Races will start from a Committee Boat located in the area between the entrance to Bembridge Harbour and either Garland or Priory Bay depending on the wind direction.

### SAILS & EQUIPMENT CHECKS

Spot checks to establish conformity with Class Rules may be made at the direction of the Race Committee before, during or after the Regatta.

## **SUPPORT BOATS**

These are welcome but are governed by EWCC SI 18.1.

## **SCORING SYSTEM**

The Low Point Scoring System (RRS Appendix A) will apply for combined prizes.

## **RESULTS**

Results will be posted on the Notice Board at BSC (and e-mailed to BHYC & SVYC) as soon as possible after each day's racing.

## **PRIZES**

Prizes will be available at BSC on completion of racing. Due to Covid-18 restrictions there will not be a formal prize giving. .

Race	<b>KEELBOAT CLASSES</b>	<b>Friday 21<sup>st</sup> Aug</b>	<b>Saturday 22<sup>nd</sup> Aug</b>
1	Handicap Cruisers	A prize	A prize
2	Redwing	Percy Browne Cup	Evelyn Moreton Cup
3	Bembridge One Design	Chetwynd Trophy	QE II Coronation Cup
4	National Squib	A prize	A prize
5	Sea View Mermaid	A prize	A prize
Race	<b>DINGHY CLASSES</b>	<b>Friday 21<sup>st</sup> Aug</b>	<b>Saturday 22<sup>nd</sup> Aug</b>
1	Optimist	A prize	A prize & Wagner Cup (1 <sup>st</sup> Overall both races); Peel Cup (1 <sup>st</sup> BSC both races)
2	Solent Scow	Scow Salver	Bennett Cup
3	Dinghy Handicap (PY 1250 and over)	A prize	A prize
4	International Laser 1 (4.7)	A prize	Astrop Cup (both races)
5	RS Feva	A prize	A prize
6	Dinghy Handicap (Under PY 1250)	A prize	Davenport Cup (both races)

C Kenyon

Rear Commodore (Sailing) BSC

# SEA VIEW YACHT CLUB REGATTA

Sunday 23<sup>rd</sup> and Monday 24<sup>th</sup> August

## NOTICE OF RACE

HIGH & LOW WATER PORTSMOUTH (BST)		
	HW	LW
Sunday 23 <sup>rd</sup> August	15:35 (4.8m)	08:19 (0.6m)
Monday 24 <sup>th</sup> August	16:29 (4.7m)	09:03 (0.8m)

### ORGANISATION

This event is organised as part of the East Wight Combined Clubs' Series. Race Management will be provided by SVYC with assistance from BSC, RVYC and BHYC.

### ELIGIBILITY & ENTRY

Helms must be members of an affiliated RYA Club. The Entry Requirements on page 2 of this programme, which includes agreement to be bound by the "Risk Statement" in EWCC SI 22 on page 28, apply. There is no Entry Fee.

### REGISTRATION & BRIEFING

In addition to complying with the entry requirements, entrants in centreboard dinghies (incl small multihulls) **must sign the Sign-On Sheet for their class at SVYC, BSC, RVYC or BHYC at least 30 minutes before the scheduled race start time.** Failure to do so will result in the boat not being recognised as racing. PYs **MUST** be entered on the appropriate Sign-On Sheet. A facility for visiting boats to sign-on on the water in the vicinity of the start line may be provided. There will not be a briefing.

### RULES & SAILING INSTRUCTIONS

Races shall be governed by the World Sailing Racing Rules of Sailing. Races will be sailed under the East Wight Sailing Instructions (which can be downloaded from <http://www.ewcc.co.uk>) as varied by this Notice of Race, except the SVOD Class which will be sailed under SVYC Sailing Instructions from a Committee Boat starting line as varied by this Notice of Race. Class flags are as shown overleaf.

### SVYC CLUB STARTING LINE

The **Orange starting line** is an extension of a line formed by bringing the SVYC flagstaff in line with an orange and white vertical marker board on the wall of the SVYC building. The Yellow Post is on an extension of this line. When starting, boats (except Cruisers) must pass between two yellow buoys marking the outer and inner limits of the line, for Cruisers the inner and outer limit marks will be inflatables placed on the seaward side of the Yellow Post. When code flag E is displayed at the warning signal the inner limit mark does not apply.



If a limit mark is lying on the pre-start side of the starting line, boats when starting shall leave on the required side both the limit mark and the point on the starting line nearest to the limit mark.

On the start line the transit lights are momentarily obscured by the SVYC flagstaff at the approximate point of transit.

The Green starting line is a line formed between the SVYC flagstaff and an outer limit Inflatable mark, there will also be an inner limit inflatable mark laid approximately on the line.

### SVYC CLUB FINISHING LINE

The Club finishing line is an extension of a line formed by bringing the SVYC flagstaff in line with an orange and white vertical marker board on the wall of the SVYC building. The Yellow Post is on an extension of this line. When finishing, boats (except Cruisers) must pass between two yellow buoys marking the outer and inner limits of the line, for Cruisers the inner and outer limit marks will be inflatables placed on the seaward side of the Yellow Post. If a white 10 on a black background is displayed Number 10 buoy becomes the outer limit mark for the finish. For all dinghies there is no inner limit mark on finishing. If a limit mark is lying beyond the finishing line, boats when finishing shall leave on the required side both the limit mark and the point on the finishing line nearest to the limit mark. **SHORTEN COURSE** In a race where a

lap finishes through the club finishing line, shortened course will be signalled by displaying flag S from ashore. In any race, the course may be shortened at a rounding mark. Boats should finish between the mark & the staff displaying flag S.

### **COURSES**

The course to be sailed will be displayed no later than four minutes prior to the waning signal. All races will start from the Club Starting Line and finish on the Club Finishing Line. EWCC SI 8.6 (boats not to pass through the start/finish line) shall not apply. All keelboat classes must pass to seaward of the following after starting: Big Ben Rock (17) Red Can, Bunch (13) Red Can, Quay Rocks (12) Red Can, Old Fort (14) Red Can, St Helen's Fort.

### **PENALTY SYSTEM**

For all classes, the EWCC Sailing Instructions are varied in that RRS 44.1 is changed so that the Two-Turns Penalty is replaced by the One-Turn Penalty (a tack and a gybe), except in the SVOD Class for a breach of RRS 18.3 (changing tack at windward mark) when a Two-Turns penalty applies.

### **PERSONAL FLOTATION DEVICES**

All competitors in centreboard dinghies, small multihulls, and windsurfers, and those required to do so under class rules, shall wear adequate personal flotation devices at all times while afloat except briefly while changing or adjusting clothing or personal equipment.

### **PROGRAMME OF EVENTS**

Race	Class	Flag	Start (both days)
1	SVOD (cadets)	W	09:30
2	Handicap Cruiser	2	10:20
3	National Squib	NN9	10:40
4	International Optimist	O	10:50
5	International Laser Handicap	1	11:20
6	Handicap Dinghy (over PY 1250)	S	12:10
7	National Squib	NN9	12:20
8	RS Feva	7	14:10
9	Handicap Dinghy (under PY 1250)	3	14:20
10	National Squib	NN9	14:40
11	Bembridge Redwing	R	14:50 (Sun) & 15:50 (Mon)
12	Bembridge One-Design	NN8	15:00 (Sun) & 16:00 (Mon)
13	SVOD Amber fleet (Committee Boat start)	W	16:30
14	SVOD Victory fleet	D	16:35

### **SAILS & EQUIPMENT CHECKS**

Spot checks to establish conformity with Class Rules may be made at the direction of the Race Committee before, during or after the Regatta.

### **SUPPORT BOATS**

These are welcome but are governed by EWCC SI 18.1 unless required to rescue a boat in trouble.

### **SCORING SYSTEM**

The Low Point Scoring System (RRS Appendix A) will apply for combined prizes.

### **RESULTS**

Results will be posted on the Notice Board at SVYC as soon as possible after the day's racing.

### **PRIZES**

Prizes for first, second and third in each race, depending on the number of entrants. These will be available at SVYC on completion of each days racing. Due to Covid-19 restrictions there will not be a formal prize giving. Trophies awarded are:

	Class	Sunday	Monday
1	SVOD (Cadets)	Cade Cups - boys/girls	Dobbs Tankard
2	Handicap Cruiser	Handicap Cruiser Cup	Ian Gilchrist Salver
3	National Squib	A prize	A prize
4	International Optimist	Simonds Cup	Simonds Cup
5	International Laser Handicap	Lakin Cup	Reynolds Cup
6	Handicap Dinghy (PY>1250)	Weir Trophy	Jim St Clair-Ford Tankard
7	National Squib	A prize	A prize
8	RS Feva	A prize	A prize
9	Handicap Dinghy (PY<1250)	Almond Cup	Hunter Cup
10	National Squib	A prize	A prize
11	Bembridge Redwing	Bizarre Bowl	Baly Beach Bell
12	Bembridge One Design	Bullin Cup	Bullin Cup
13	SVOD Amber fleet	Sir Edward Blount Cup	Sir Edward Blount Cup
14	SVOD Victory fleet	Gordon Walker Salver	Victory Cup

In addition to the above prizes and trophies, the following trophies will be awarded:

Laser Pico	David Farquhar Cup (1 <sup>st</sup> in H'cap Dinghy PY>1250 race - Sunday)
	Brandt Cup (1 <sup>st</sup> in H'cap Dinghy PY>1250 race - Monday)
	Casey Cup (4 race series)
National Squib	The Squib Model (4 race series with 1 discard)
	Sallemanda Trophy (1 <sup>st</sup> SVYC boat for 6 race series with 1 discard over 4 days of BSC and SVYC regattas)

J Curtis - Sailing Director SVYC



# BRADING HAVEN YACHT CLUB REGATTA

*(incorporating the Mermaid Gin Regatta)*

Sunday 23<sup>rd</sup> August - Dinghies

Saturday 29<sup>th</sup> and Sunday 30<sup>th</sup> August - Keelboats

## NOTICE OF RACE

<i>HIGH &amp; LOW WATER PORTSMOUTH (BST)</i>		
	HW	LW
Sunday 23 <sup>rd</sup> August	15:35 (4.8m)	08:19 (0.6m)
Saturday 29 <sup>th</sup> August	09:24 (4.0m)	14:46 (1.8m)
Sunday 30 <sup>th</sup> August	10:38 (4.2m)	15:43 (1.6m)

### ORGANISATION

This event is part of the East Wight Combined Clubs' Series. The Organising Authority will be BHYC with race management assistance provided by BSC for the Keelboat Class events.

### ELIGIBILITY & ENTRY

Helms must be members of an affiliated RYA Club. The Entry Requirements on page 2 of this programme, which includes agreement to be bound by the "Risk Statement" in EWCC SI 22 on page 28, apply. There is no Entry Fee.

### REGISTRATION & BRIEFING

In addition to complying with the entry requirements, **entrants in centreboard dinghies (incl small multihulls) must sign up online (separate instructions will be issued by BHYC) at least 30 minutes before the scheduled race start time.** Failure to do so will result in the boat not being recognised as racing. PYs **MUST** be entered for Races 1 & 3. There will not be a briefing.

### RULES & SAILING INSTRUCTIONS

Races shall be governed by the World Sailing Racing Rules of Sailing 2017-2020, RYA Prescriptions, Class Rules, this Notice of Race and the Sailing Instructions. Races will be sailed under the East Wight Sailing Instructions, as varied by this Notice of Race. They can be downloaded from <http://www.ewcc.co.uk>

Class flags are as shown below. Races will be started in accordance with RRS 26; however, there will be a 5 minute gap between the start of each Keelboat Class and the warning for the next one - this modifies RRS 26. Rule 44.1 is changed so that the Two-turns Penalty is replaced by a One-turn Penalty.

<b><i>DINGHY CLASSES (Sunday 23<sup>rd</sup> August)</i></b>				
<i>Race</i>	<i>Class</i>	<i>Flag</i>	<i>Sun (23<sup>rd</sup> Aug)</i>	
1	Dinghy Handicap (under PY 1250) incl Lasers	3	14:30	
2	RS Feva	F	14:35	
3	Dinghy Handicap (PY 1250 and over)	4	14:40	
4	Solent Scow	7	14:45	
5	Optimist	O	14:50	
6	Swan	Z	14:55	
<b><i>KEELBOAT CLASSES (Saturday &amp; Sunday 29<sup>th</sup> - 30<sup>th</sup> August)</i></b>				
<i>Race</i>	<i>Class</i>	<i>Flag</i>	<i>Sat (29<sup>th</sup> Aug)</i>	<i>Sun (30<sup>th</sup> Aug)</i>
1	Bembridge Redwing	R	09:00	09:30
2	Bembridge One Design	NN8	09:10	09:40
3	Seaview Mermaid	9	09:20	09:50

## **COURSES**

**Keelboat Classes** - Races will start from the BSC Committee Boat Starting Line positioned off St Helens Fort.

**Dinghy Classes** - Races will start from a Committee Boat located in the area between the entrance to Bembridge Harbour and either Garland or Priory Bay depending on the wind direction.

## **SAILS & EQUIPMENT CHECKS**

Spot checks to establish conformity with Class Rules may be made at the direction of the Race Committee before, during or after the Regatta.

**SUPPORT BOATS** - these are welcome but are governed by EWCC SI 18.1 unless required to rescue a boat in trouble.

**SCORING SYSTEM** - the Low Point Scoring System (RRS Appendix A) will apply for combined prizes.

**RESULTS** - Results will be posted on the Notice Board at BHYC as soon as possible after each day's racing.

**PRIZES** - Prizes will be available for collection after racing from organising Clubs. Due to Covid-19 restrictions there will not be a formal prize giving.

## **INSHORE CLASSES**

<b>Race</b>	<b>Class</b>	<b>Sunday (23<sup>rd</sup> Aug)</b>
1	Dinghy Handicap (under PY 1250) incl Lasers	Ted Eyre-Williams Cup A prize for the 1 <sup>st</sup> Laser
2	RS Feva	tbc
3	Dinghy Handicap (PY 1250 and over)	Seawych Jubilee Cup
4	Solent Scow Wooden Scow	BHYC Scow Regatta Cup Gabbani Woody Cup
5	Optimist	Mander Cup
6	Swan	Vivian Lloyd Regatta Cup

## **KEELBOAT CLASSES**

<b>Race</b>	<b>Class</b>	<b>Saturday (29<sup>th</sup> Aug)</b>	<b>Sunday (30<sup>th</sup> Aug)</b>
1	Bembridge Redwing	A prize	Loch-Nell Trophy (both days)
2	Bembridge One Design	Selwyn Cup	Hector Humphray Cup
3	Seaview Mermaid	A prize	Mermaid Gin

P Schafer  
Rear Commodore (Sailing) BHYC

C Kenyon  
Rear Commodore (Sailing) BSC

# EWCC MOCRA BEMBRIDGE REGATTA (*incorporating MOCRA Nationals*)

Saturday 12<sup>th</sup> & Sunday 13<sup>th</sup> September

## NOTICE OF RACE

### ORGANISATION

This event is part of the East Wight Combined Club's series. The Organising Authority will be BSC.

### CONDITIONS OF ENTRY & ENTRY FEE

The Entry Requirements on page 2 of this programme and the Risk Statement in EWCC SI 22 apply. Both can be downloaded from <http://www.ewcc.co.uk>. The Entry Form will be available from BSC and must have been returned to the Mike Samuelson, c/o Bembridge Sailing Club by 4<sup>th</sup> September along with the Entry Fee of £50.00. There will be a surcharge of £10.00 for late entries received after cop 4<sup>th</sup> September.

All boats shall have a valid 2020 MOCRA, DIAM 24od or RTIR Bridge Deck Cruiser Rating Certificate.

### REGISTRATION & BRIEFING

Registration and a briefing will be held on Friday evening 11<sup>th</sup> September. Boats arriving on Saturday morning prior to Race 1 must report in to the Committee Boat (SEA BREEZE) on arrival off Bembridge (**Ch 77**).

### SAILING INSTRUCTIONS

Races shall be governed by the World Sailing Racing Rules of Sailing 2017 - 2020, RYA Prescriptions, MOCRA Rules, DIAM 24od Class Rules, this Notice of Race and the Sailing Instructions. EWCC SIs will apply as varied by this Notice of Race. SIs can be downloaded from <http://www.ewcc.co.uk>.

The following Class Flags will be used: MOCRA - **M**

### PROGRAMME OF EVENTS

Date & HW (Portsmouth)		Timings	Events
Fri 11 <sup>th</sup> Sep	HW 18:23 (3.8m) LW 11:01 (2.1m)	On arrival	Registration
		20:00	Supper (pay as you go) & Briefing for those who are available
Sat 12 <sup>th</sup> Sep	HW 07:05 (3.7m) LW 12:52 (2.2m) HW 19:43 (3.7m)	11:00	MOCRA Race 1 (c 60 mins) - windward/leeward
		oc	MOCRA Race 2 (c 90 mins) - longer distance
		14:30	MOCRA Race 3 (c 60 mins) - windward/leeward
		oc	To Bembridge Harbour (beach/pontoons as required)
		20:00	Regatta BBQ
Sun 13 <sup>th</sup> Sep	HW 09:11 (3.8m) LW 14:20 (2.1m) HW 21:30 (3.9m)	10:30	MOCRA Race 4 (c 45 mins) - round the buoys
		oc	MOCRA Race 5 (c 90 mins) - longer distance
		oc	Return to home ports

### SAILS, EQUIPMENT CHECKS & SAFETY

Boats shall comply with the current World Sailing Special Regulations for Category 4 races, except that regulations 3.13.1 (crash bulkheads), 3.15.2(c) and (d) (netting triangles), 3.14.4(c) (trimaran outrigger lines) and 3.14.4(d) (lifelines on catamarans) shall not apply. Spot checks to establish conformity with Class Rules may be made at the direction of the Race Committee before, during or after the Regatta.

DIAM 24ods shall carry a righting line & will put one reef in their mains in the event of the wind speed being 20 knots or more - signified by the Committee Boat displaying Numeral 7 and announcing on Ch 77.

### COURSES & RACE FORMAT

The Eastern Solent south/south west of the Warner and Nab East Buoys. A list of all likely marks with GPS co-ordinates will be e-mailed to competitors separately; inflatable marks may be used. EWCC Special Courses 1, 5 or 6 may be used. Boats shall not pass between St Helens Fort and Nodes Point during racing.

Scoring races will be run as an Average Lap format for MOCRA boats. For these races, competitors are required to repeat the course as notified to include the start/finish line at the end of each lap. Competitors will finish when the shortened course flag is displayed as they cross the start/finish line (irrespective of the number of laps completed). Clarification if necessary will be provided on VHF Ch 77.

## **STARTING**

Races will be started in accordance with RRS 26 modified so that the Warning Signal for each MOCRA start shall be displayed 10 mins before the Start; the Preparatory Signal will be displayed 4 mins before the Start.

## **EXONERATION PENALTY, ADVISORY HEARING & RYA ARBITRATION**

The exoneration Penalty and Advisory Hearing & RYA Arbitration of the RYA Rules Disputes Procedures will be available. This extends SI 15.

## **SCORING**

Low Point Scoring System (RRS Appendix A) will apply. There will be one discard if 4 or more races are completed.

## **PRIZES**

The "Samuelson Trophy" for the overall winner will be presented at the MOCRA AGM & Prize Giving Dinner being held later in the year.

Providing there are sufficient entries, prizes (provided by BSC) will be awarded to the winners of each race.

## **COMMUNICATIONS**

Race Information - Ch 77; Race Management - M2; Bembridge Harbour/Marina - Ch 80

## **BERTHING**

Berthing requirements must be indicated on the Entry Form; a limited number of overnight moorings will be available Under Tyne.

## **MEALS**

Meal requirements for the Regatta should be entered on the back of the Entry Form. These must be confirmed and paid for prior to arrival.

## **CANCELLATION**

*In* the event that the Regatta is cancelled because BSC has to close as a COVID-19 measure, a full refund will be given; otherwise no refunds will be made after 4<sup>th</sup> September.

C Kenyon  
Rear Commodore (Sailing), BSC

S Baker  
for MOCRA



*Vintage Apple Bitter*  
**MERRY  
DOWN**



Saturday 19<sup>th</sup> & Sunday 20<sup>th</sup> September

**NOTICE OF RACE**

<i>HIGH &amp; LOW WATER PORTSMOUTH (BST)</i>	<i>LW</i>	<i>HW</i>	<i>LW</i>
Saturday 19 <sup>th</sup> September	06:35 (0.3m)	13:30 (5.0m)	18:56 (0.5m)
Sunday 20 <sup>th</sup> September	07:15 (0.4m)	14:15 (5.0m)	19:37 (0.5m)

**ORGANISATION**

This event is part of the EWCC Regatta Series. The organising authority will be RVYC.

**ELIGIBILITY AND ENTRY**

Entry is open to Cruisers (multihull and monohull), which will be dual scored using MOCRA or VPRS ratings and handicaps, Dayboats and Dinghies. Helms must be members of RYA-affiliated clubs.

**RULES**

Racing will be governed by the rules defined in the 2017-2020 World Sailing Racing Rules of Sailing (RRS), RYA Prescriptions, Class Rules, RVYC Race Chart 2020 and this Notice of Race (except where modified by the RVYC MR 2020 SIs) and the RVYC Merrydown Regatta 2020 Sailing Instructions (RVYC MR 2020 SIs) which replace the EWCC Regatta Series 2019 Sailing Instructions. In a case of conflict, the RVYC MR 2020 SIs will apply. The RVYC MR 2020 SIs will be available by 1 August 2020 from the RVYC website or office.

**PROGRAMME OF EVENTS**

Saturday 09:30 Briefing  
10:30 first race (tbc)  
Sunday 11:00 first race (tbc)

Each day, there will be one long race for Cruiser classes and a maximum of three short races for other classes including Scows. The details of classes will be set out in the RVYC MR 2020 SIs.

**COURSES**

Racing (except for Scows which will race in Wootton Creek) will be started and finished at the RVYC Race Box to the west of Wootton Creek or from a Committee Boat. Courses will be in the Eastern Solent in accordance with the RVYC Race Chart 2020.

**RESULTS AND PRIZES**

Results will be published on the RVYC website and on the Regatta Notice Board as soon as possible. Prizegiving will be held as soon as possible after the results have been finalised on Sunday 20<sup>th</sup> September.

**INSURANCE**

Each participating boat shall be insured with valid third-party liability insurance with a minimum cover of £2,000,000.

For further information, please check <https://www.rvyc.org.uk/open-events/regattas> or contact the RVYC on 01983 882325 or email [office@rvyc.org.uk](mailto:office@rvyc.org.uk)

Jane Barrett Bellingham - Rear-Commodore Sailing, RVYC

## **EWCC SAILING INSTRUCTIONS 2020**

### **1 RULES**

- 1.1 Except where amended by these Sailing Instructions (SIs), all races will be governed by the rules as defined in the current Racing Rules of Sailing.
- 1.2 When sailing in the deep water channel boats are required to give way to large vessels (commercial & naval) proceeding either to and from the ports of Portsmouth and Southampton or the anchorage at St Helen's Roads.
- 1.3 Each boat sailing in a Class or under the Handicap for that Class shall comply with its Class Rules, which will take precedence. All boats must carry the minimum buoyancy required under their Class Rules (or as built, in the absence of any specific Class Rule).
- 1.4 For all competitors an adequate personal flotation device shall be carried on board, and these shall be worn at all times while afloat, except briefly while changing or adjusting clothing or personal equipment, if
- (i) they are competing in centreboard dinghies, or small multihulls or
  - ii) they are under 18 in any class, or
  - iii) class rules require it, or
  - iv) flag Y is displayed ashore or from the committee boat;
- This changes the preamble to part 4 and RRS 40.
- An adequate flotation device is a life-jacket or buoyancy aid to a minimum of 50 Newtons EN393/ISO12402-5, or 100 Newtons for weak swimmers or non-swimmers.
- 1.5 Racing rules will be changed as follow.
- Definition of AP (displayed ashore - one hour's notice after removal)
  - RRS 33 (course change for courses using specified racing marks)
  - RRS 35 (time limit for handicap races)
  - RRS 61.1 (protest notification for boats under 6 metres)
  - RRS 66 (re-opening hearing on last day of a regatta)
- 1.6 In races for Handicap Cruisers the handicap will be as set out in the Entry Requirements on Page 2. In races for handicap dinghies, the Portsmouth Yardstick of the boat, as amended by the organising Club(s) will be used.

### **2 NOTICES TO COMPETITORS**

- 2.1 Notices to competitors will be posted on the official notice board located at the organising Club(s).

### **3 CHANGES TO SAILING INSTRUCTIONS**

- 3.1 Changes to the SIs made prior to 3 hours before the scheduled starting time of a race will be posted in accordance with SI 2.1 except that any change in the schedule of the races will be posted by 18:00 on the day before it will take place. Changes made less than 3 hours before the scheduled starting time of a race will be written on a board displayed on the Committee Boat and indicated by displaying flag 2<sup>nd</sup> Substitute with two sounds.

### **4 SIGNALS MADE FROM ASHORE**

- 4.1 Signals made from ashore will be flown from the flagstaff of the organising Club(s).
- 4.2 Code Flag AP flown from the flagstaff of the organizing Club(s) with two sound signals means the race is postponed. The Warning Signal for any subsequent Committee Boat starts will be made not less than one hour after the AP is lowered with one sound signal (This changes Flag AP).

### **5 SCHEDULE OF RACES**

- 5.1 The schedule of races is as given in the Notice of Race.

### **6 CLASS FLAGS**

- 6.1 Class Flags will be as in the Notice of Race.

### **7 RACING AREA**

- 7.1 The racing area will be in the Eastern Solent (see EWCC chart on the cover of this Programme or RVYC chart).

### **8 THE COURSE**

- 8.1 The Course to be sailed will be displayed by letters, numbers or symbols listed with these SIs no later than the Preparatory Signal. This changes RRS 27.1

- 8.2 A RED or ORANGE Background to the letter, number or symbol indicates that the buoy shall be rounded to PORT. A GREEN background to the letter, number or symbol indicates that the buoy shall be rounded to STARBOARD. If a board and markers is used then all marks shall be rounded to STARBOARD unless UNDERLINED when they shall be rounded to PORT.
- 8.3 If two DIAMONDS are displayed on the Course Board, the sequence before the diamonds shall be sailed twice before continuing to the marks displayed after the diamonds. If three DIAMONDS are displayed on the Course Board, the sequence before the diamonds shall be sailed thrice before continuing to the marks displayed after the diamonds.
- 8.4 When a BLACK AND ORANGE CHEQUERED board is displayed in the Course, the mark(s) preceding this board will be rounded before rounding the marks displayed after the chequered board for the number of times indicated.
- 8.5 spare.
- 8.6 For all races run from a Committee Boat, after starting, no boat shall pass through the Starting Line on any leg. Unless varied by the display of Course Board £, no boat shall pass through the Finishing Line except when finishing (see SI 12.1). After starting and until finishing, the Starting and Finishing Lines will rank as obstructions under RRS 18 and 19. (**NB** The starting and finishing line exists for so long as the Committee Boat is on station and is flying an *orange* flag for a starting line and orange (or orange and blue) or S flag for finishing line)
- 8.7 **SPECIAL COURSES**
- 8.7.1 **Special Course 1** will be a windward/leeward course with a wing mark as described in Appendix 1.1. This will be signalled from the committee boat by displaying a course board with a 1 on it followed by the marks to be rounded in accordance with Appendix 2.
- 8.7.2 **Special Courses 2, 3 & 4** will be a trapezoid course as shown in Appendix 1.2. These will be signalled from the committee boat by displaying a course board with a 2, 3 or 4 on it. Inflatable marks will be used.
- 8.7.3 **Special Course 5** will be a windward/leeward course with a leeward finish as shown in Appendix 1.3. This will be signalled from the committee boat by displaying a course board with a 5 on it. The number of rounds to be sailed will be indicated by the number of diamonds displayed on a course board. If a windward spreader, a leeward spreader and/or a leeward gate is to be used, this will be signalled from the Committee boat in accordance with Appendix 2.
- 8.7.4 **Special Course 6** will be a windward/leeward course with a windward finish as shown in Appendix 1.3. This will be signalled from the committee boat by displaying a course board with a 6 on it. The number of rounds to be sailed will be indicated by the number of diamonds displayed on a course board. If a windward spreader, a leeward spreader and/or a leeward gate is to be used, this will be signalled from the Committee boat in accordance with Appendix 2.
- 8.7.5 For Special Courses 1, 5 & 6, the start and finish lines may be placed at any point between the windward and leeward marks shown in the diagrams in Appendices 1.1 & 1.3.
- 8.7.6 In the event that one of the gate marks is missing, the remaining mark shall be rounded to port.
- 9 **MARKS**
- 9.1 Marks of the Course will be either inflatable moveable buoys, or navigation buoys or marks permanently laid as shown on the chart of the area reproduced on the cover of this programme and listed in Appendix 2. The Finishing Mark is described in SI 12.
- 10 **THE START**
- 10.1 Races will be started in accordance with RRS 26 (unless varied in the Notice of Race).
- 10.2 The Orange Flag will be displayed (with one sound signal) 5 minutes before the warning signal of the first race. It will be removed when all starters have crossed the line.-
- 10.3 Boats whose Warning Signal has not been made shall keep clear of the starting area.
- 10.4 A boat shall not start later than 4 minutes after her starting signal for a 5 minute starting sequence or 9 minutes after her starting signal for a 10 minute starting sequence.
- COMMITTEE BOAT STARTING LINE**
- 10.5 Unless otherwise indicated in the Notice of Race a Committee Boat Starting Line will be used.
- 10.6 The Committee Boat Starting Line will be between a staff displaying an Orange Flag on the Committee Boat at the starboard end, and the Course side of the Outer Limit Mark at the port end.
- 10.7 The starting mark will be the Committee Boat together with a RIB or inflatable buoy if attached to the Committee Boat.

10.8 The Committee Boat may hold position by using engines.

## 11 CHANGES OF COURSE AFTER THE START

11.1 A change of course after the start will be signaled before the leading boat has begun the leg, although the new mark may not then be in position. Code Flag C will be flown and either the new Course to be sailed from the mark where it is displayed or the approximate compass bearing to the new mark (or a red rectangle for a change to port or a green triangle for a change to starboard) and a + or – sign to indicate the lengthening or shortening of a leg. This changes RRS 33. A periodic Sound Signal will be made. Any mark to be rounded after rounding the new mark may be relocated to maintain the original Course configuration without further signals. When in a subsequent change of Course a new mark is replaced, it will be replaced with the original mark.

11.2 Minor mark moves (up to approximately 100 metres) may be made without signalling the change. This changes RRS 33.

## 12 FINISH

12.1 Unless otherwise indicated in the Course instructions, the Finishing Line will be between the mast or staff flying an ORANGE flag on the Finishing Committee Boat (which **may** fly a BLUE Flag to signify that it is in position) and the Course side of the Finishing Mark. Except in the case of Special Courses 1, 2 & 3 the Finishing Mark is the last mark of the Course shown, or for a shortened Course the adjacent rounding mark. When the last mark of a course or round is displayed using Course Board £, the outer distance mark is a laid buoy and boats must pass through this finishing line at the end of each round. The S Flag may be substituted for the ORANGE Flag if the Course is shortened.

12.2 The Finishing Committee Boat may be held position by using engines.

## 13 PENALTY SYSTEM

13.1 Unless otherwise indicated in the Notice of Race or disallowed under Class Rules, RRS 31 (touching a mark - a one-turn penalty to include one tack & one gybe) and 44.1 (breaking a Part 2 Rule - a two-turn penalty to include two tacks & two gybes) apply.

## 14 TIME LIMIT

14.1 The time limit for any Class will be 3 hours after the actual start of that Class.

14.2 Boats failing to finish within the time limit or 30 minutes (60 minutes for handicap cruisers) after the first boat sails the course and finishes whichever is later will be scored DNF. This changes RRS 35. A4 and A5.

14.3 Should no boat finish within the Time Limit, the result of the race for that class may be determined from a previously recorded time for all boats (taken at the finishing line or rounding mark). This changes RRS 35, A4 and A5.

## 15 PROTESTS

15.1 RRS 61.1 applies with the following change; boats under 6m which are not required to display a Red Protest Flag shall inform the Race Officer immediately after finishing that they wish to bring a protest. Protests must be submitted in writing within the time limits set out in RRS 61.3. Advisory Hearings and/or the RYA Arbitration Procedure may be available in accordance with the protocol available at the organising Club(s).

15.2 The Jury will hear protests in approximately the order of receipt as soon as possible.

15.3 Protest notices will be posted within 30 minutes of the protest time limit to inform competitors where and when there is a hearing in which they are parties to a hearing or named as witnesses.

15.4 RRS 66 is changed by adding the following sentence - "On the last day of racing, a party to the hearing may ask for a reopening no later than 1 hour after being informed of the decision."

## 16 SCORING

16.1 RRS Appendix A, the low point scoring system will apply, unless the Class Rules state otherwise.

## 17 OFFICIAL BOATS

17.1 Craft owned by the organising clubs will normally be used; if private craft are used they will identify themselves to competitors.

## 18 SUPPORT BOATS

18.1 Team leaders, coaches and other support personnel shall not be in the racing area from the time of the Preparatory Signal for the first Class to start until all boats have finished or the Race Committee



signals a postponement, general recall or abandonment. The penalty for failing to comply with this requirement will be the disqualification of all boats associated with the support personnel involved.

## 19 **TRASH**

19.1 Trash may be placed aboard support or official boats.

19.2 The penalty for breaking rule 55, Trash Disposal, is at the discretion of the protest committee (DPC) and may be less than disqualification.

## 20 **RADIOS AND MOBILE PHONES**

20.1 The use of VHF radio or mobile phones to gain information that may assist a boat to improve its position is not allowed. However unless modified in the NoR, all keelboat, cruisers & cruising multihulls (including Diam 24od or equivalent) shall carry a VHF radio & listen on Channel 77 so that safety & race management information may be passed.

20.2 Use of the code word "Code Red" may be used to signify an emergency during racing; until cancelled by the controlling station, radio silence should be observed by those not involved in the emergency. The name of the Club should also be used in the initial transmission.

## 21 **DECLARATIONS, RETIREMENTS, RESULTS & PRIZES**

21.1 Any boat, which crosses the Finishing Line and does NOT signify EITHER that she has retired OR that she is protesting in accordance with RRS 61.1(a) shall be deemed to have completed the race in accordance with the Sailing Instructions. Declarations will NOT be required.

21.2 Boats retiring shall report their retirement to the organising Club at the earliest opportunity: BSC (01983 872237) - SVYC (01983 613268) - BHYC (01983 872289) - RVYC (01983 882325)

21.3 Results will be posted on the official Notice Board of the organising Club(s) & their websites.

21.4 Prize details are given in the Notice of Race.

## 22 **RISK STATEMENT**

22.1 RRS 4 states: "The responsibility for a boat's decision to participate in a race or to continue racing is hers alone." Sailing is by its nature an unpredictable sport and therefore involves an element of risk. By taking part in the event, each competitor agrees and acknowledges that:

22.2 They are aware of the inherent element of risk involved in the sport and accept responsibility for the exposure of themselves, their crew and their boat to such inherent risk whilst taking part in the event;

22.3 They are responsible for the safety of themselves, their crew, their boat and their other property whether afloat or ashore;

22.4 They accept responsibility for any injury, damage or loss to the extent caused by their own actions or omissions;

22.5 Their boat is in good order, equipped to sail in the event and they are fit to participate;

22.6 The provision of a race management team, patrol boats, umpires and other officials and volunteers by the organiser does not relieve them of their own responsibilities;

22.7 The provision of patrol boat cover is limited to such assistance, particularly in extreme weather conditions, as can be practically provided in the circumstances;

22.8 Their boat is adequately insured, with cover of at least £2 million against third party claims.

22.9 It is their responsibility to familiarise themselves with any risks specific to the event that are drawn to their attention and to attend any safety briefing held before the event.

# Special Course 1

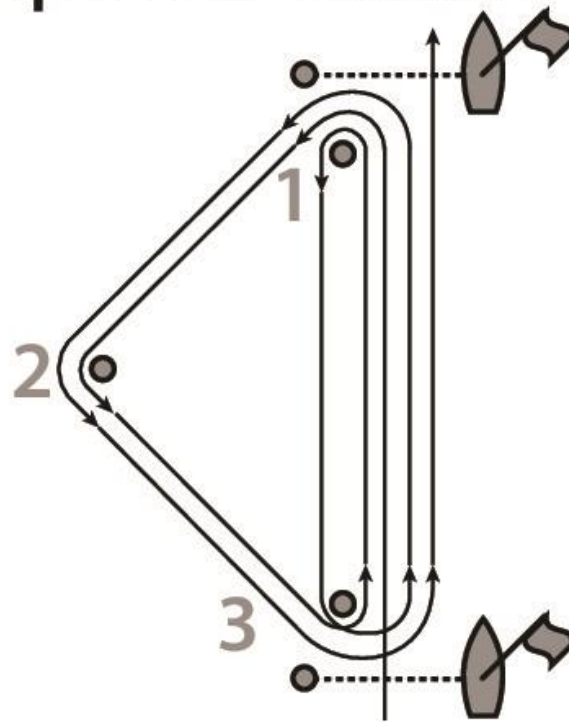

Start -1-2-3-1-3-1-2-3-Finish

*The Finish Committee Boat **may** be positioned between Marks 1 & 2.*

## Special Course 2

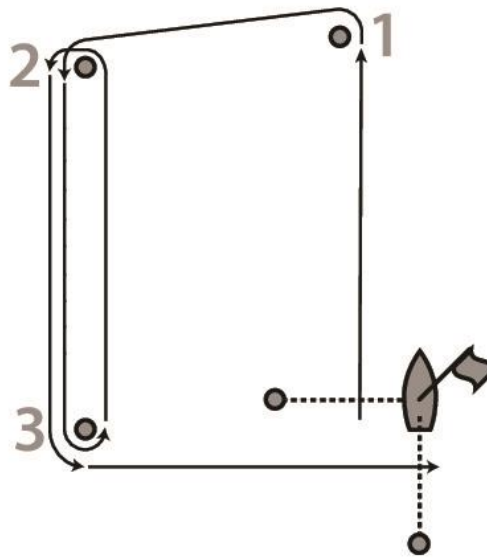

Start - 1-2-3-2-3-Finish

## Special Course 3

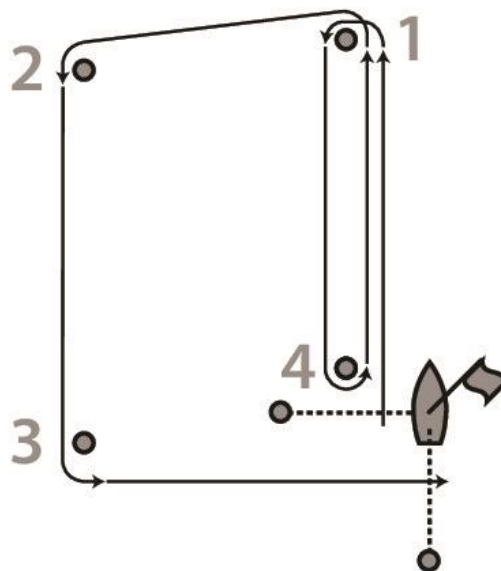

Start - 1-4-1-2-3-Finish

# Special Course 4

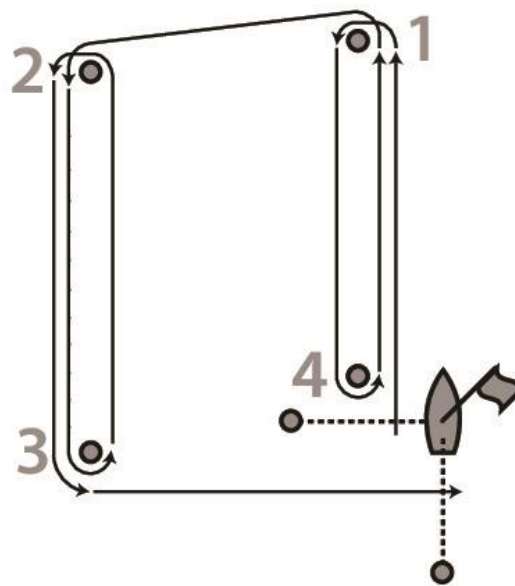

Start -1-4-1-2-3-2-3-Finish

## Special Course 5

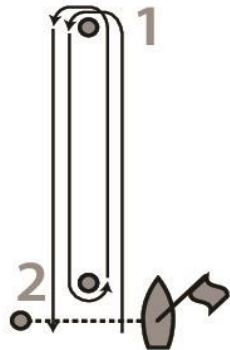

1 Round: Start -1-Finish

2 Rounds: Start -1-2-1- 2-Finish

*The Start & Finish Committee boat may be positioned in the middle of the upwind leg*

*In the event of there being a leeward gate, boats must pass through it on the way to the finish line*

*Number of rounds indicated by the number of diamonds on a course board. The following course boards may also be used:*

**+W = Windward spreader**

**+L = Leeward spreader**

**+G = Leeward gate**

## Special Course 6

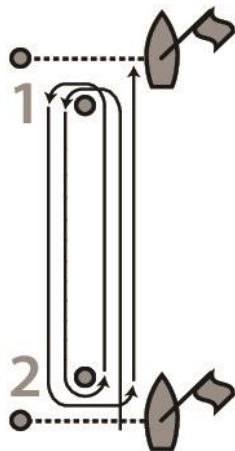

1 Round: Start -1-2-Finish

2 Rounds: Start -1-2-1- 2-Finish

*The Start & Finish Committee boat may be positioned in the middle of the upwind leg*

*In the event of there being a windward gate, boats must pass through it on the way to the finish line*

EWCC RACING MARKS WITH ALLOTTED LETTERS, NUMBERS AND SYMBOLS		
A	ACLAND	Yellow Spherical/N-Cone
B	BRITTEN	Yellow Spherical/Black Vertical Line (new)
C	COCHRANE	Yellow Spherical (new)
D	DRUMHEAD	Yellow Spherical (new)
E	SPY ALARMS (ex-UNDER TYNE)	Yellow Spherical (new)
F	FITZWILLIAM	Yellow Spherical (new)
G	GARLAND	Yellow Spherical (new) with White Band
H	BRADING HAVEN TURNING MARK	Yellow Spherical
I	NAB EAST	Red Channel Buoy
J	JONAH	<del>Yellow Spherical</del>
JJ	JANSON (ex-PATCH)	Yellow Spherical with Black Band
jh	JENNY HUNTER	<del>Yellow Spherical</del>
K	DERRICK	Yellow Spherical with Orange Band (new)
L	SEA VIEW LINE	Yellow Post
M	MORETON	Yellow Spherical (new) with Orange Band
N	NAINBY LUXMOORE	Yellow Spherical (new)
O	OLD CHURCH	Yellow Top Hat Buoy
Q	St HELENS	Red Channel Buoy
R	RUTHVEN	Yellow Spherical (new)
S	LOLLIPOP	Yellow Spherical
T	TARA	Yellow Spherical
U	SOMERS	<del>Yellow Spherical</del>
V	BEMBRIDGE LEDGE	Yellow/Black East Cardinal
W	WRECK	<del>Yellow Spherical</del>
X	WARNER	Red Pillar Buoy
Y	FOOTPRINT	Yellow Top Hat Buoy
Z	NAB END	Red Pillar Buoy
!	NAB TOWER	Nab Tower
2	BRUCE	<del>Yellow Spherical</del>
3	BERTIE	Inflatable
4	PIERHEAD	<del>Yellow Spherical</del>
6	BROOKIE	Yellow Stripes
7	OUTER MARK	Yellow Spherical
8	LITTLE DEB	<del>Yellow Spherical</del>
9	GORDON	Red Can
11	OLD 'O'	Yellow Top Hat Buoy
15	BOOM	Yellow Top Hat Buoy
16	MAUDESLEY	Inflatable
	BUNNY	<del>Yellow Spherical</del>
ILM(10)	SVYC INNER LINE (Orange Start)	Orange Dan Buoy
ILM(22)	SVYC INNER LINE (Green Start)	Green Dan Buoy
#	PEPE	Yellow Top Hat Buoy
□	BEMBRIDGE TIDE GAUGE	
□	INFLATABLE MARK TO WINDWARD [OPTIONAL 2 □s FOR A DISTANT MARK]	
□	INFLATABLE MARK TO LEEWARD [OPTIONAL 2 □s FOR A DISTANT MARK]	
□ □	INFLATABLE WING MARK	
□	<b>LAID OUTER LIMIT MARK (COMMITTEE BOAT START/FINISH)</b>	
£	<b>BOATS MUST GO THROUGH THE FINISH LINE ON EACH ROUND</b>	
+W	<b>WINDWARD SPREADER MARK (Special Courses 5 &amp; 6)</b>	
+L	<b>LEEWARD SPREADER MARK (Special Courses 5 &amp; 6)</b>	
+G	<b>GATE MARK (Special Courses 5 &amp; 6)</b>	